

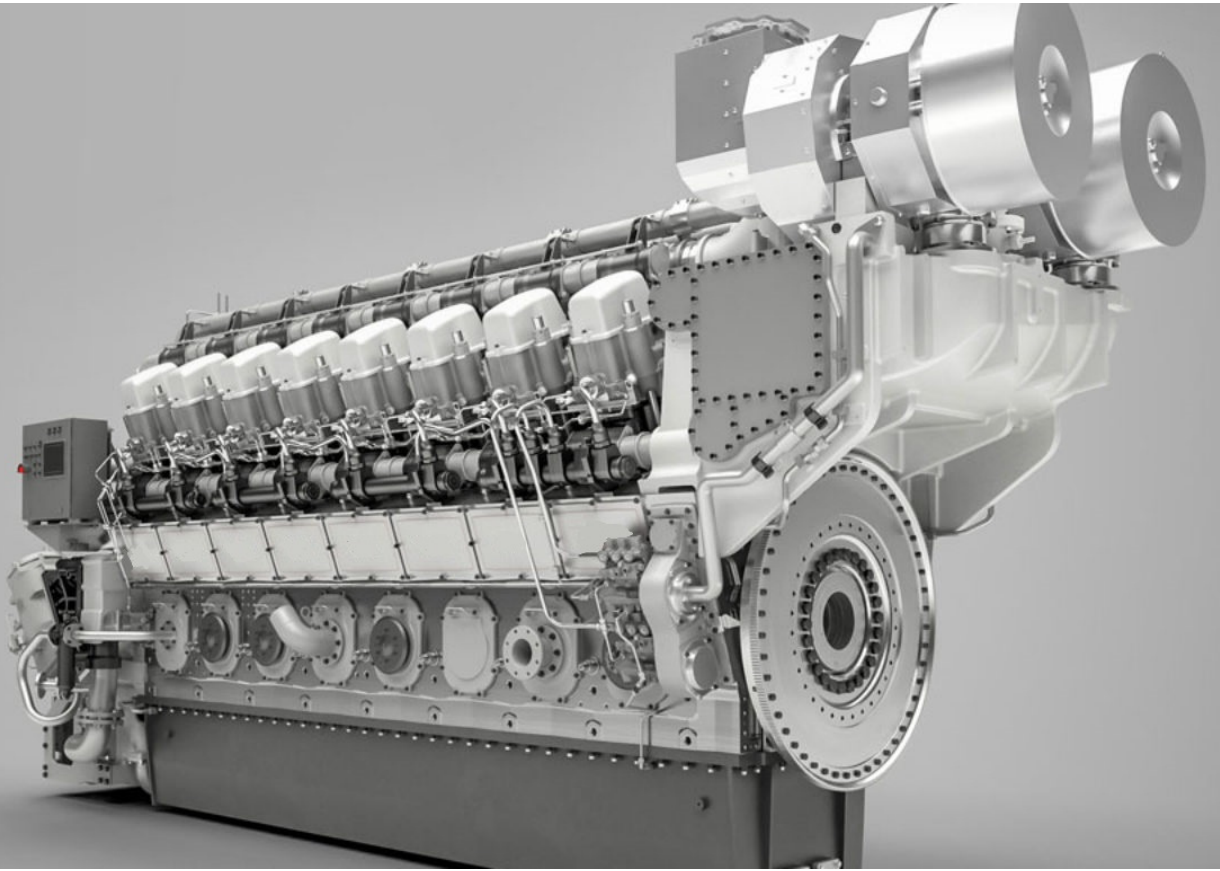

Go Deep Inside the
Industrial Machines

Sense Freely
Self-Powered
Wireless-Batteryless
Sustainable Solution for Industry 4.0

CONNECTING ROD MONITORING



ESCOM Enhanced Solutions

The Future of Wireless - Batteryless Energy Harvesting Sensing Technologies

ESCOM-ES is the R&D center founded in 2018 and owned by ESCOM Power Plants Engineering Services. We are focusing on and developing Self Powered – Wireless - Batteryless Sensors which is eliminating all wiring and cabling cost and workmanship which can reach many kms in a simple industrial plant. And offering smart and green solutions getting rid of batteries and cables...

No Battery - No Cable - No Wiring

ESCOM-ES offers a wide range of domestic and industrial sensing systems that can be used in harsh environment harvests its own power from ambient sources such as motion, temperature, sunlight, magnetic fields, or where energy is available to scavenge...

Self-powered, wireless sensing technology, combined with engineering expertise and rich analytics provide real-time information for our customer's needs...



SUSTAINABLE MEASUREMENT TECHNOLOGY

Industry-specific Solutions

We produce innovative and economical industrial solutions specific to the problems occurring in internal combustion engines. We ensure that physical information such as temperature, pressure, required in risky areas that are difficult to access in internal combustion engines are received and monitored securely.



What is CoRoM?

Objective:

Main purpose of CoRoM is to succeed receiving and monitoring temperature directly from Diesel Engine connecting rod upper bearing shell and optionally measure the piston lubrication oil temperature, so that to provide vital data of ;

- connecting rod upper bearing shell condition (the most critical point)
- any bearing seizure at very early stage
- continuous control & monitoring of con-rod bearing and oil temperature

by Wireless & Batteryless Sensing Node with Energy Harvesting System, and transferring all data via Wi-Fi / BLE to the Main Control Panel to establish preventive, informative and protective early warning system and try to minimize the Connecting Rod Bearing and Piston Failures encountered in diesel engines.

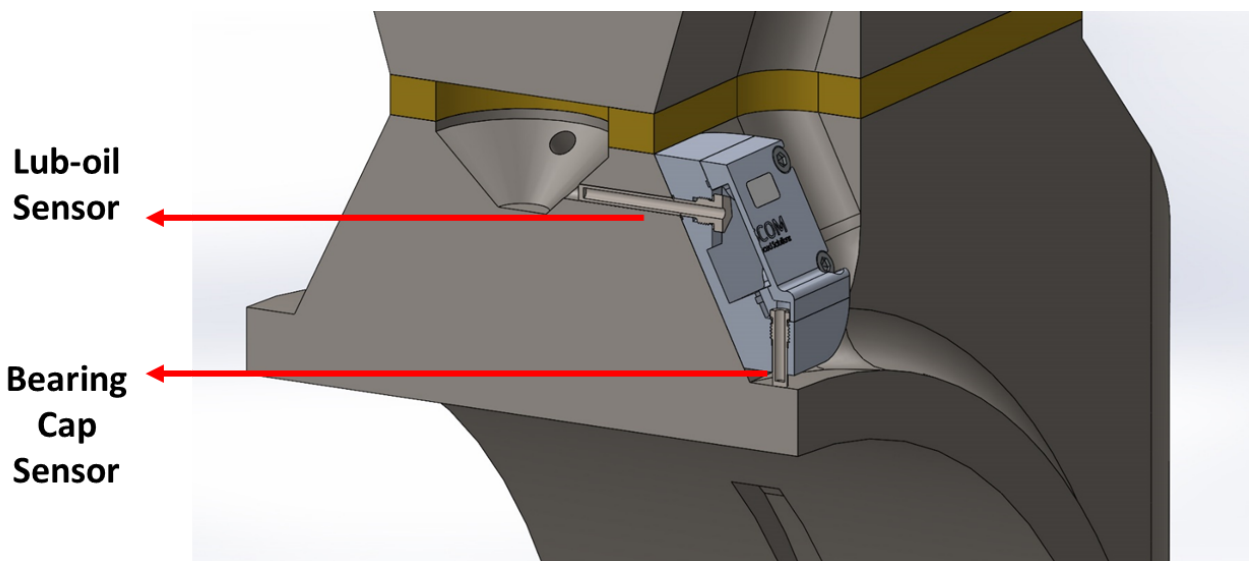

CoRoM Bearing Cap sensor

The temperature of ConRod upper bearing shell is measured by a PT100 sensor, located in the groove of ConRod upper cap with or without drilling a hole to get upper bearing shell temperature

CoRoM Lub-oil sensor

CoRoM Lub-oil sensor, measures the lube oil temperature going upwards to piston crown by a PT100 sensor. The sensor hole is drilled vertically on the upper cap of ConRod to reach the oil passage.

Installation of CoRoM?

CoRoM is located in the groove of ConRod upper cap and installed by 4x M6 bolts

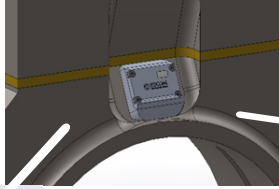
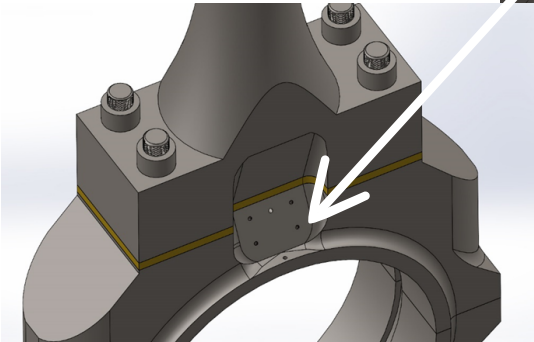

Evaluation of CoRoM data

Slight or sudden increase in CoRoM Bearing Cap sensor, is an indication about siezing of ConRod upper bearing shell temperature.

Increase in CoRoM Lub-oil temperature will provide an additional data about the ConRod bearing condition.

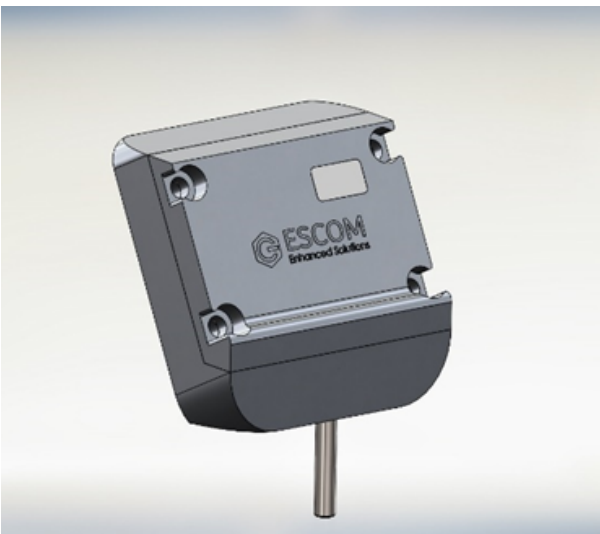
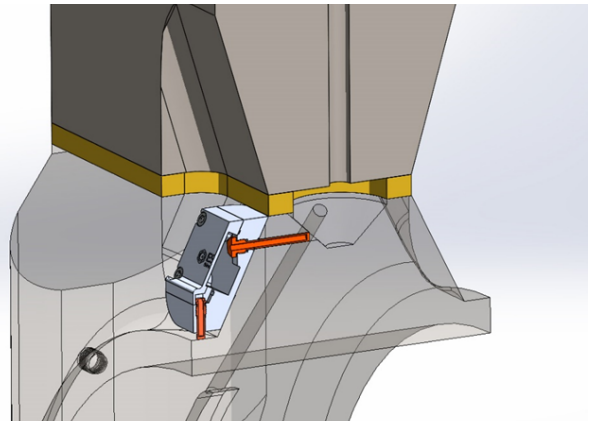

Advantages of CoRoM

- CoRoM is a system that has not been developed until now in diesel engine technology, and is able to obtain data directly from the ConRod bearing.
- CoRoM will give us faster and more accurate data, early warning before the failure happen comparing to existing temperature Splash Oil Monitoring or Oil Mist Monitoring systems
- Wireless, battery-free, able to generate its own energy.
- CoRoM will provide proactive approach and preventive maintenance ability by continious monitoring

SPLASH OIL and OIL MIST MONITORING SYSTEMS ;

- Existing Splash Oil Monitoring System is to receive data from the splashing oil unclear from where it has splashed at that moment will give us a common alarm and needs to be checked whether a failure in the liner, piston rings, or skirt, or connecting rod bearing or any.
- SPMS or OMD is able to give alarm after the failure happened
- But CoRoM will give us data directly from the source and will establish a much better, safer and faster analysis opportunity before the failure reached to the crankshaft.



Thanks to CoRoM, by this very specific continuous measurement we will have a chance to minimize the cost, time and generation loss of malfunction of connecting rod bearing, with a preventive, predictive and superior technological approach.

INDUSTRIAL IoT

Wireless BatteryLess Sensors & Network

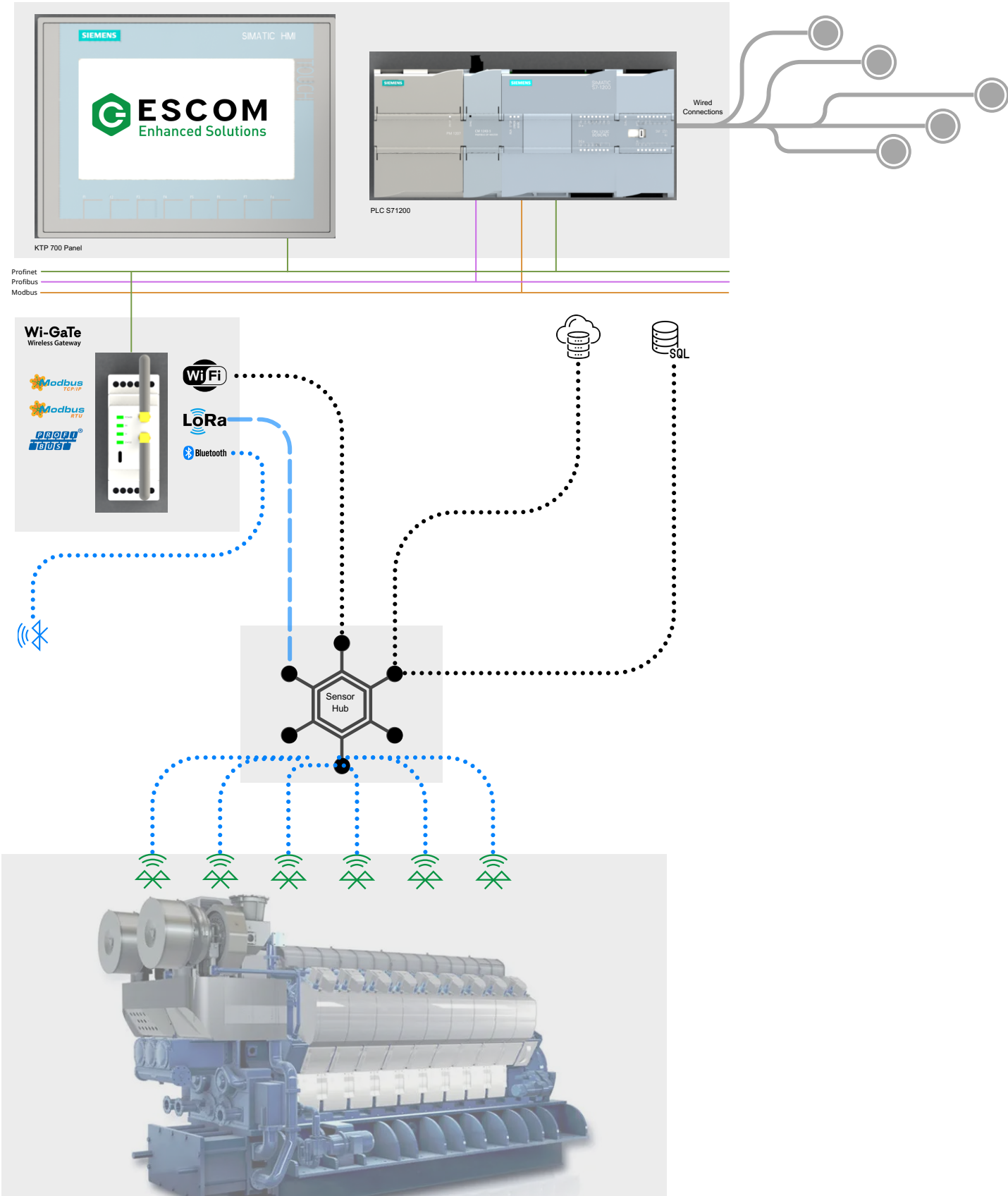



✉ info@escom-es.com

📍 Fertek Mah. OSB 7.cad No:16/1 51100 Nigde TURKIYE

🌐 www.escom-es.com

